

PRB

ROBOT PALLETIZER FOR BOXES

Technical data	PRB
Cycles/minute	8
Set up power	15 Kw
Voltage	380 Volt
Air consumption	150 l./min.

OPTIONAL

- Layer sheet dispenser and relevant magazine
- Pallet magazine
- Pallet conveyor

Automatic machine suitable to palletise shrinkpacks, cartons or other kinds of packed products. Operator interface (HMI), for the management of the whole line, with control for start, stop, size change operations, manual movement, machine diagnostics, alarms and further visual and acoustic signals. The product is fed to the machine by a synchronising conveyor and transferred onto a collecting top with a device for the product spacing. The gripper head can collect one or two packs at a time and by means of axes system driven by brushless motors it will deposit them onto the pallet according to the pre-set configuration.

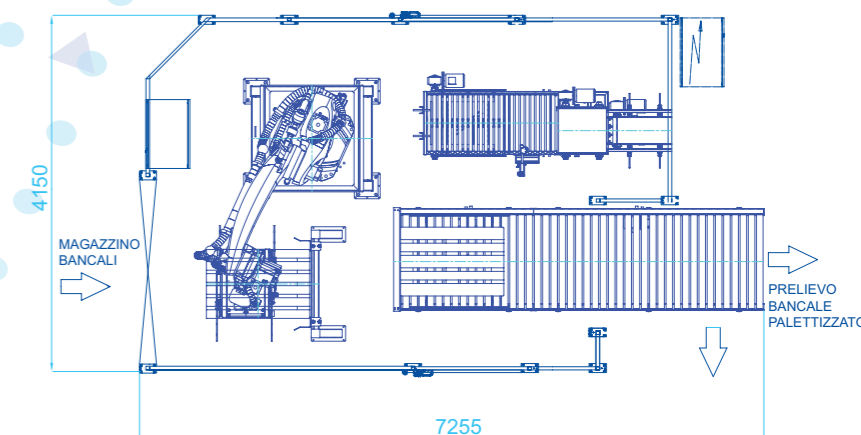
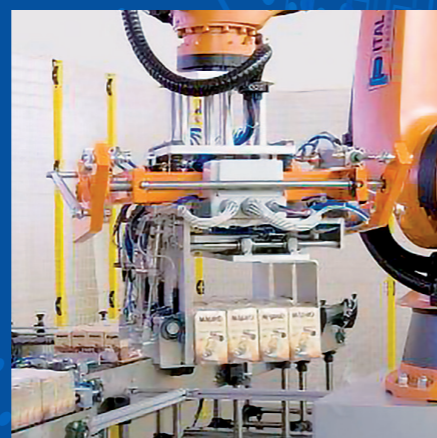

HIGH TECH ENGINEERING