

**PKR**

# ROBOT CARTONING MACHINE

**OPTIONAL**

- Continuous divider
- Head / Screw conveyor trolley
- Quick shift changeover

Anthropomorphic robot cartoner with 6 axes for packaging and wrapping lines. Thanks to the robot ergonomics and speed, the cartoner is able to complete one to more cartons at the same time. The cartoning island consists of a routing conveyor working continuously and capable of shunting the items from one to more rows in quick and smooth actions. Having sorted the items, the robot picks the pattern by means of a purpose-designed gripper, and lowers it into cartons which were previously erected and sealed at their bottom. If needed, the robot will be able to replace its own gripper automatically thanks to implemented quick couplings. By means of proper carriages, placed in the robot pick-up area, it will be possible to replace the head in operation with the head for a new pattern.



Technical data	PKR
Cases/minute	15-50
Set up power	10 Kw
Voltage	380 Volt
Air consumption	500 l./min.

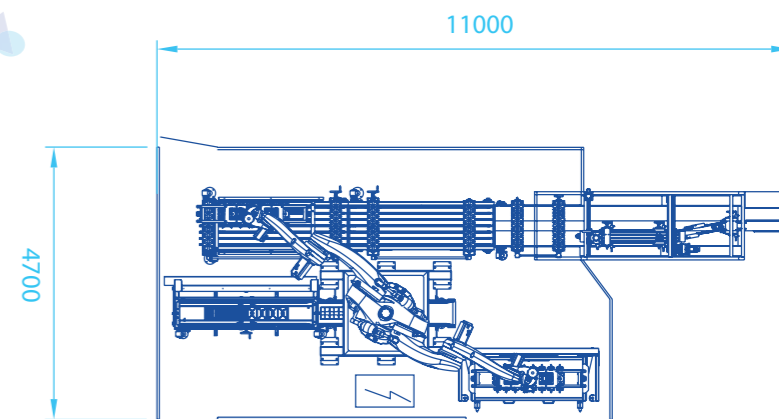

HIGH TECH ENGINEERING